

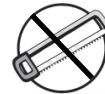


# 4" Oval Straight Side Bar

Part No. A1553S /T



Fits: 2020 GLADIATOR



60-180 min

Cutting Not Required

Drilling Not Required



REMOVE CONTENTS FROM BOX. VERIFY ALL PARTS ARE PRESENT.



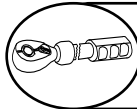
support@trailfx.com



READ INSTRUCTIONS CAREFULLY BEFORE STARTING INSTALLATION.



1 866 638 4870



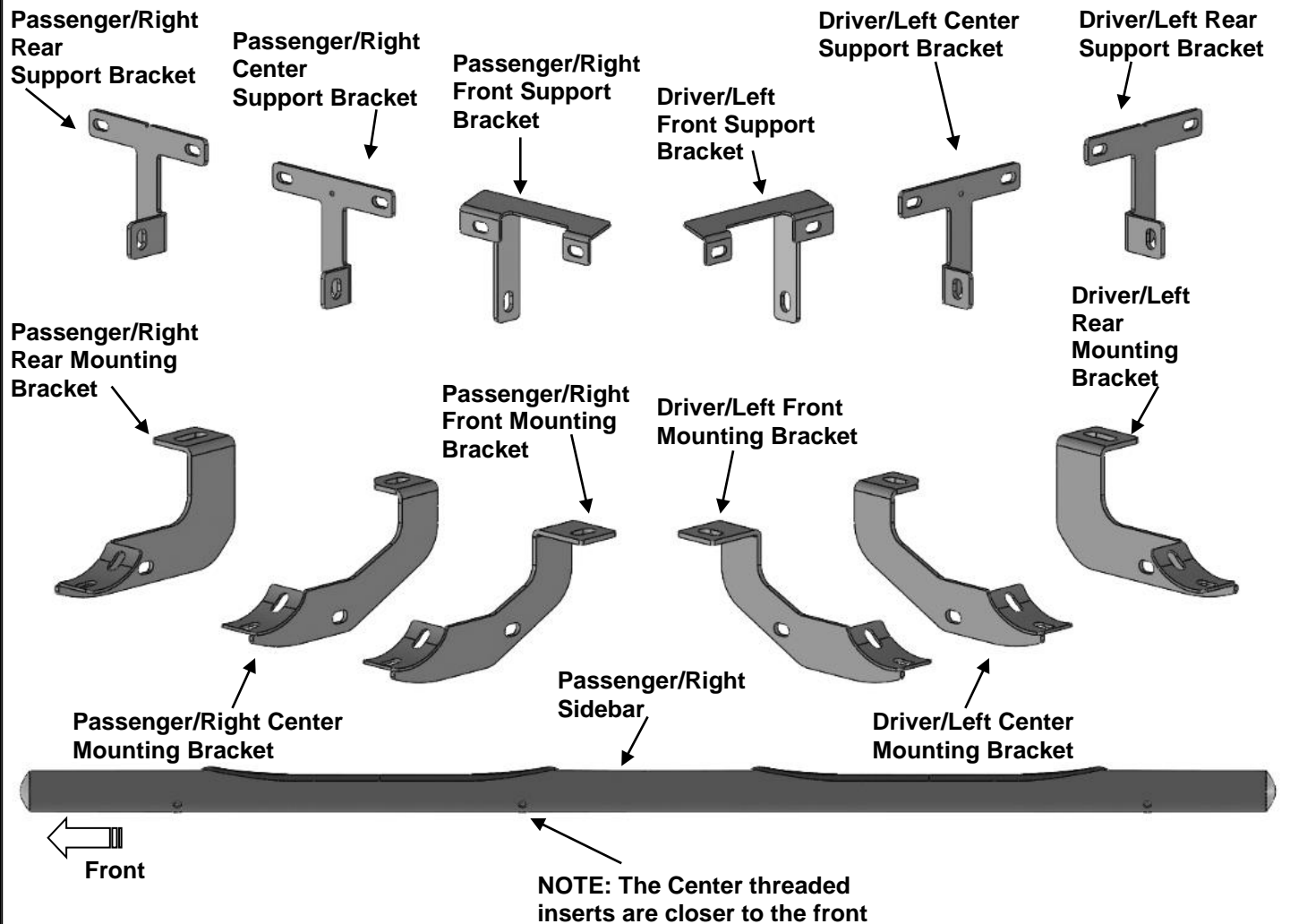
DO NOT OVER TORQUE. STANDARD OPERATING LOAD FOR TIGHTEN BODY MOUNT NUTS & BOLTS VARIES FROM 45 TO 65 FOOT POUND.



POLISHED STAINLESS STEEL – LIMITED LIFETIME  
POWDER COATED BLACK – 3 YEARS

### PARTS LIST:

Qty	Part Description	Qty	Part Description
1	Driver/Left Sidebar	1	Driver/Left Rear Support Bracket
1	Passenger/Right Sidebar	1	Passenger/Right Rear Support Bracket
1	Driver/Left Front Mounting Bracket	6	10-1.5mm x 30mm Hex Bolts
1	Passenger/Right Front Mounting Bracket	12	10mm x 24mm x 2.2mm Flat Washers
1	Driver/Left Center Mounting Bracket	6	10-1.5mm Nylon Lock Nuts
1	Passenger/Right Center Mounting Bracket	12	8-1.25mm Combo Bolts
1	Driver/Left Rear Mounting Bracket	6	8-1.25mm x 35mm Hex Bolts
1	Passenger/Right Rear Mounting Bracket	6	8mm Lock Washers
1	Driver/Left Front Support Bracket	6	8mm x 28mm x 3mm Flat Washers
1	Passenger/Right Front Support Bracket	12	6-1.0mm x 25mm Hex Bolts
1	Driver/Left Center Support Bracket	24	6mm x 22mm x 2mm Flat Washers
1	Passenger/Right Center Support Bracket	12	6-1.0mm Nylon Lock Nuts

**PROCEDURE:**

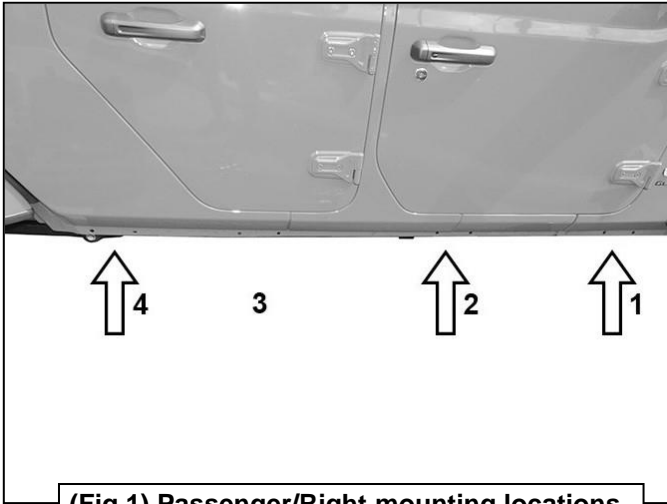
- 1. REMOVE CONTENTS FROM BOX. VERIFY ALL PARTS ARE PRESENT. READ INSTRUCTIONS CAREFULLY BEFORE STARTING INSTALLATION. SIDE STEPS OR RUNNING BOARDS MUST BE REMOVED BEFORE INSTALLATION.**
- Start installation on the Passenger/Right front of the vehicle. Find the front threaded insert located in between the first pair of holes along the pinch weld, **(Figure 2)**. Installation will use the 1st, 2nd and 4th mounting locations, **(Figure 1)**.
- Select the Passenger/Right Front Mounting Bracket, **(Figure 3)**. **IMPORTANT:** Use the illustration above and **Figure 3** to properly identify the Mounting Bracket. Attach the Mounting Bracket to the threaded insert using (1) 8mm x 35mm Hex Bolt, (1) 8mm Lock Washer and (1) 8mm Flat Washer, **(Figures 4 & 5)**. Do not tighten hardware.
- Select the Passenger/Right Front Support Bracket. **IMPORTANT:** Use the illustration above to help identify the correct Support Bracket. Attach the Support Bracket to the pinch weld using (2) 6mm Hex Bolts, (4) 6 mm Flat Washers and (2) 6mm Nylon Lock Nuts, **(Figure 6)**. **NOTE: Insert bolts from the outside of the pinch weld and through the Bracket.** Attach the Support Bracket to the Mounting Bracket with (1) 10mm Hex Bolt, (2) 10mm Flat Washers and (1) 10mm Nylon Lock Nut, **(Figures 7 & 8)**. Do not tighten hardware.
- Move to the 2nd mounting location and locate the threaded insert and pair of holes in the pinch weld, **(Figure 9)**. Repeat **Steps 3 & 4** to install the Passenger/Right Center Mounting and Support Brackets, **(Figures 3, 10—12)**. **NOTE: The Center and Rear Mounting Brackets look similar but each one is unique. The Center Support Bracket has a hole in the top and a notch on the bottom. The Rear Support Bracket has a notch at the top, (Figure 11).** Do not tighten hardware.
- Move to the last mounting location on the rocker panel and locate the threaded insert and pair of holes in the pinch weld, **(Figure 13)**. Repeat **Steps 3 & 4** to install the Passenger/Right Rear Mounting and Support Brackets, **(Figures 3, 11 & 14)**. Do not tighten hardware.
- Select the Passenger/Right Sidebar. Use the illustration above to select the correct Sidebar. Carefully position the Sidebar onto the (3) Mounting Brackets. **IMPORTANT:** Do not slide, (front to back or rotate), the Sidebar on the Brackets or damage to the finish on the Sidebar may result. Attach the

Sidebar to the Mounting Brackets with (6) 8mm x 25mm Combo Bolts, **(Figure 15)**. Do not tighten hardware.

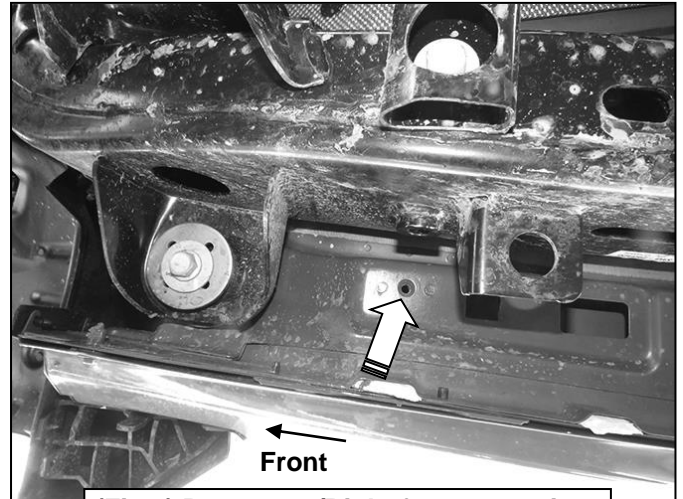
8. Level and adjust the Sidebar and tighten all hardware.
9. Repeat **Steps 2—8** for Driver/Left Sidebar installation.
10. Do periodic inspections to the installation to make sure that all hardware is secure and tight.

**To protect your investment**, Do not use any type of polish or wax that may contain abrasives that could damage the finish. Mild soap may be used to clean Sidebar.

### Passenger/Right Side Installation Pictured



**(Fig 1) Passenger/Right mounting locations**



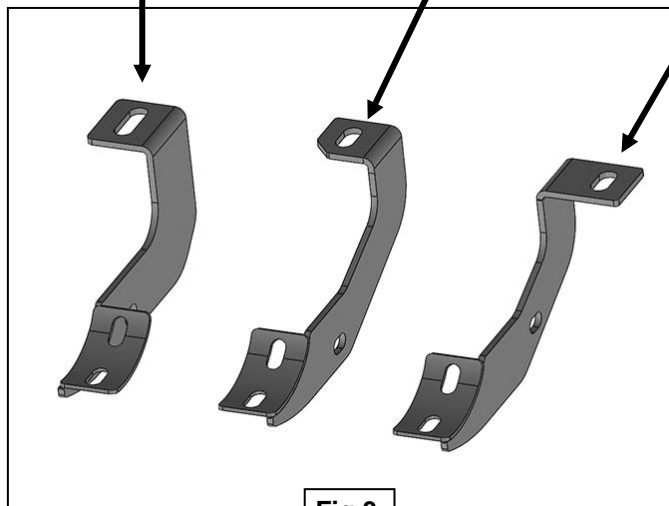
**(Fig 2) Passenger/Right front mounting location with threaded insert**

### Passenger/Right Side Installation Pictured

Passenger/Right Rear Mounting Bracket has a tab that faces backward

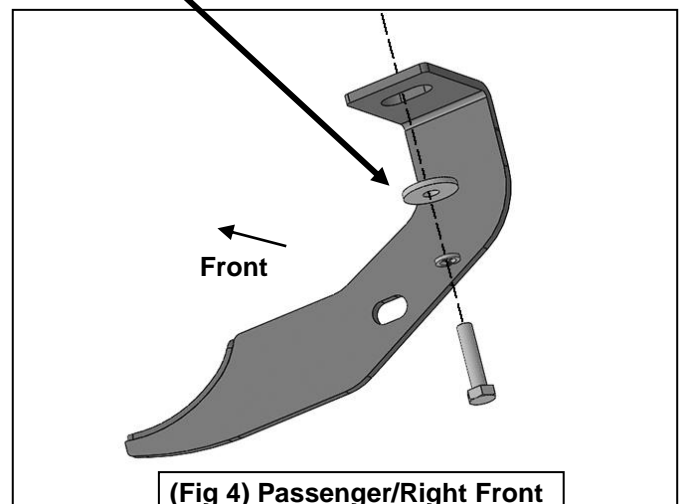
Passenger/Right Center Mounting Bracket has a tab that faces backward and a notch

Passenger/Right Front Mounting Bracket has a tab that faces forward

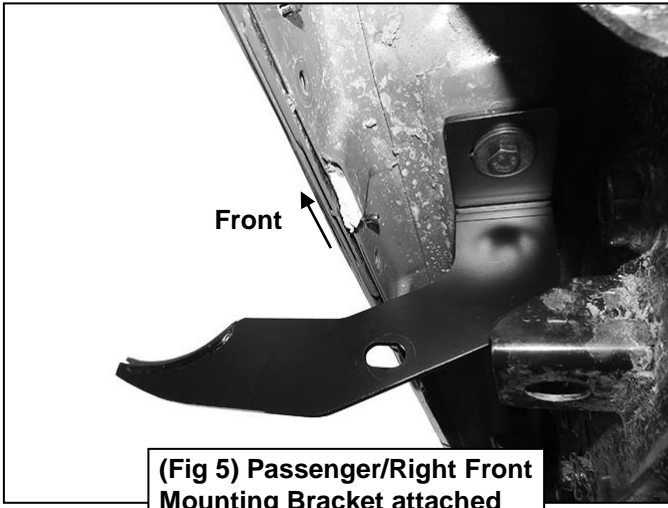


**Fig 3**

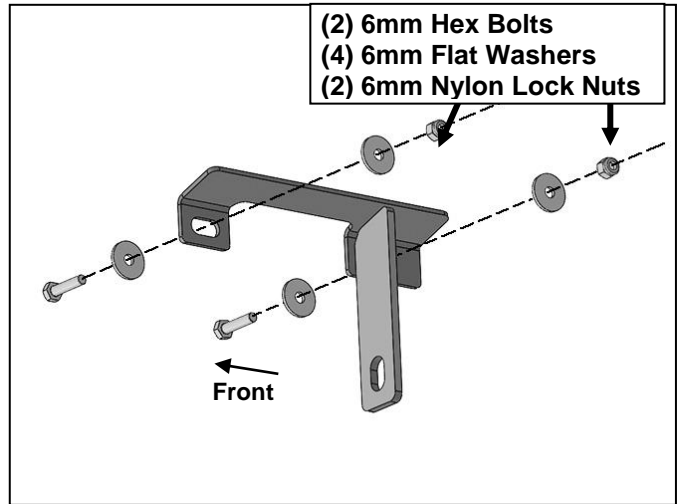
- (1) 8mm x 35mm Hex Bolt
- (1) 8mm Lock Washer
- (1) 8mm Flat Washer



**(Fig 4) Passenger/Right Front Mounting Bracket installation**

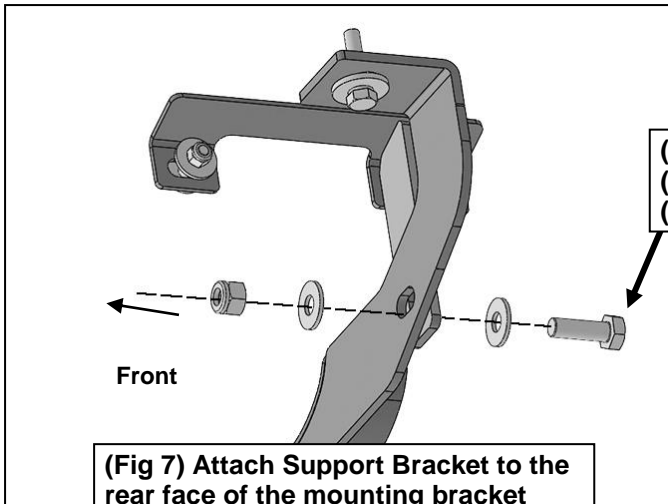


(Fig 5) Passenger/Right Front Mounting Bracket attached

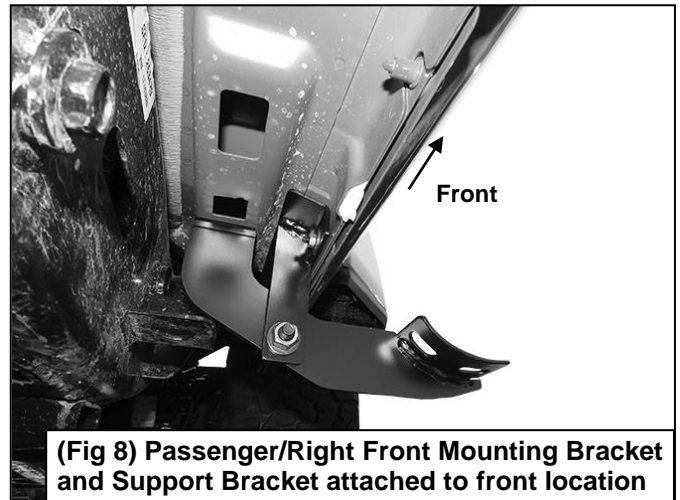


(Fig 6) Attach Support Bracket to back of pinch weld

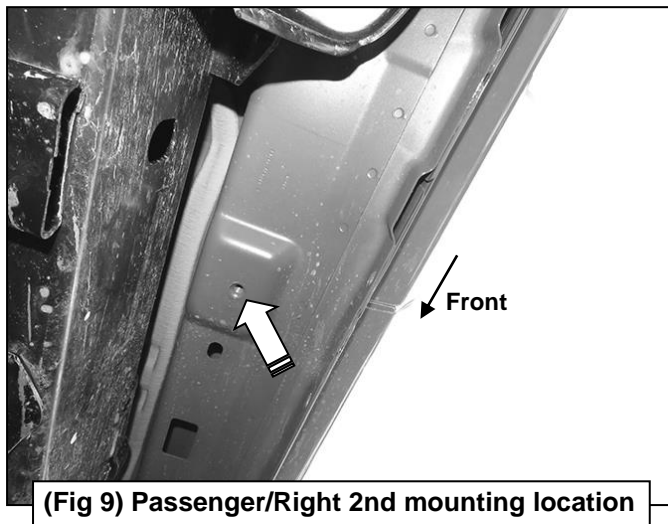
Passenger/Right Side Installation Pictured



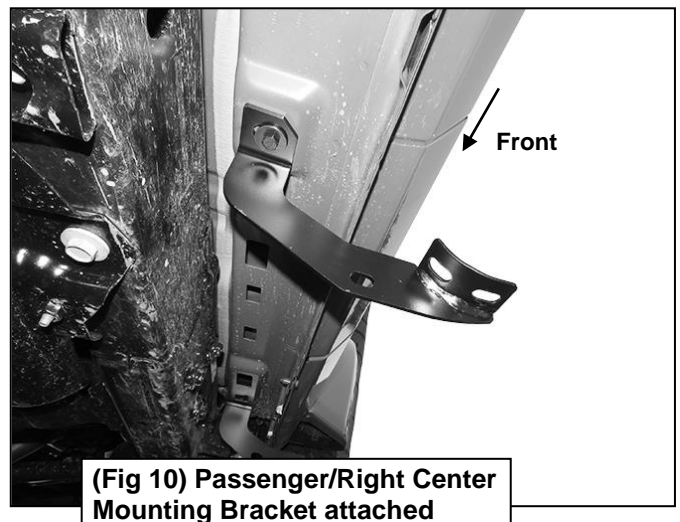
(Fig 7) Attach Support Bracket to the rear face of the mounting bracket



(Fig 8) Passenger/Right Front Mounting Bracket and Support Bracket attached to front location



(Fig 9) Passenger/Right 2nd mounting location



(Fig 10) Passenger/Right Center Mounting Bracket attached

### Passenger/Right Side Installation Pictured

The Rear Support Bracket has a notch in the top.

The Center Support Bracket has a hole in the top. It also has a notch at the bottom

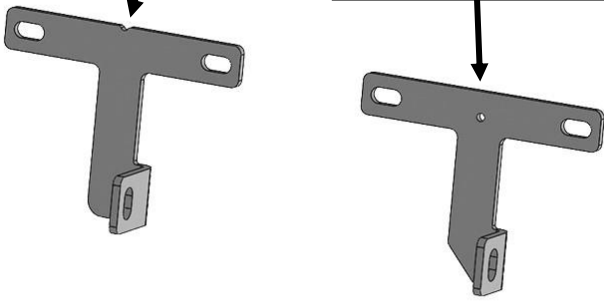
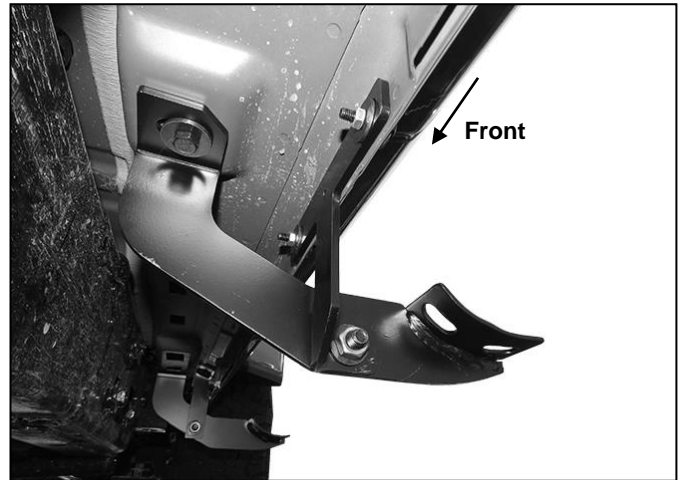
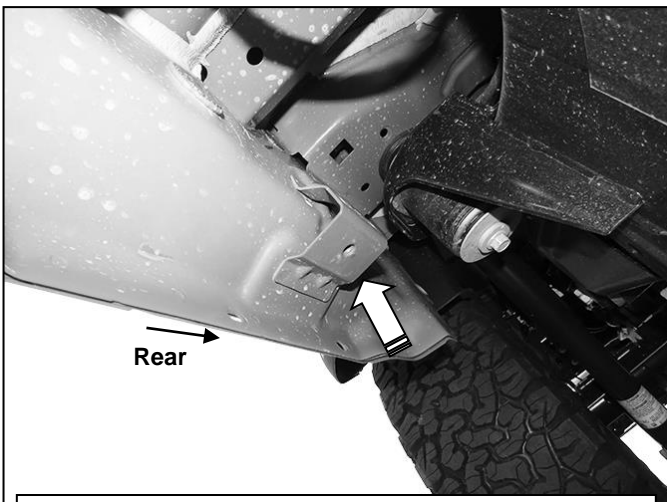


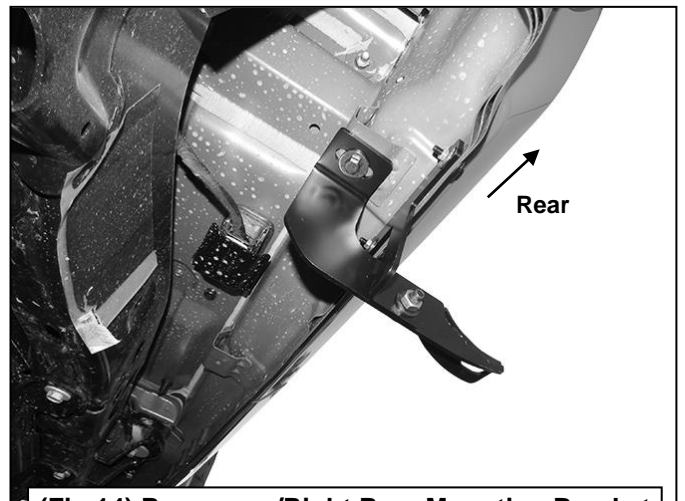
Fig 11



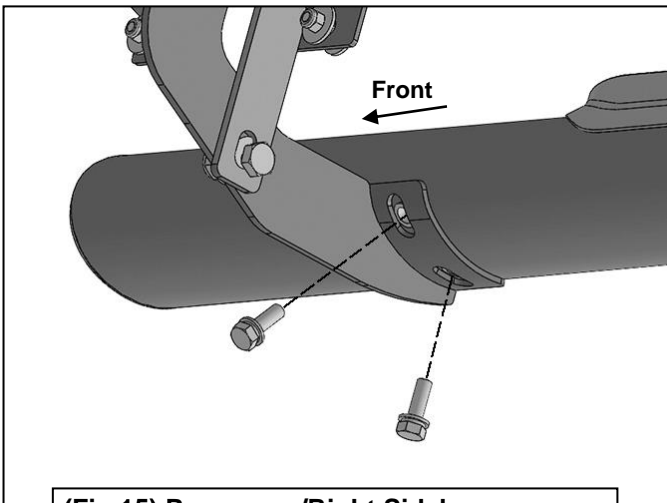
(Fig 12) Passenger/Right Center Mounting Bracket and Support Bracket attached to 2nd location



(Fig 13) Passenger/Right rear mounting location



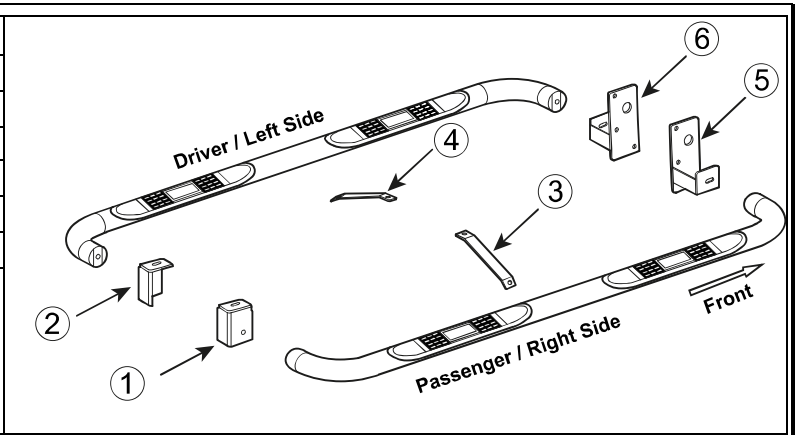
(Fig 14) Passenger/Right Rear Mounting Bracket and Support Bracket attached to rear location



(Fig 15) Passenger/Right Sidebar installation (Passenger/Right front shown)

No.	Parts Identification
1	Passenger / Right 'Rear' Bracket marked "PR"
2	Driver / Left 'Rear' Bracket marked "DR"
3	Passenger / Right 'Center' Bracket marked "PC"
4	Driver / Left 'Center' Bracket marked "DC"
5	Passenger / Right 'Front' Bracket marked "PF"
6	Driver / Left 'Front' Bracket marked "DF"

**Note:**  
 > This guide is to identify the parts and not a reference for part count.  
 > For part count, refer Parts List.  
 > Product / Bracket image is representative and actual design may vary.



**PRODUCT CARE**

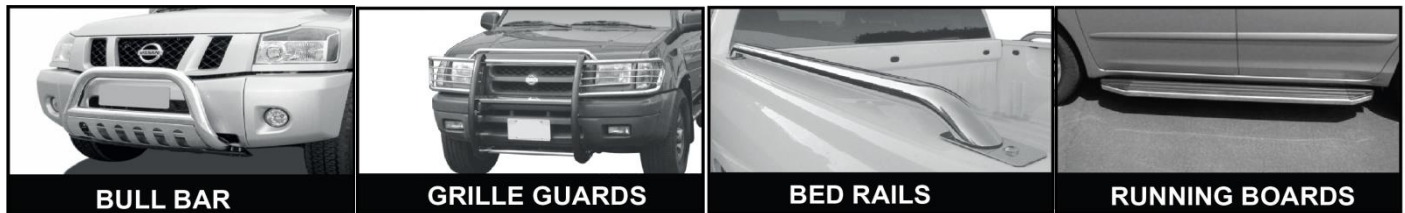
- Periodically check the product to ensure all fasteners are tight and components are intact.
- Regular waxing is recommended to protect the finish of the product.
- **Use ONLY Non-Abrasive automotive wax.** Use of any soap, polish or wax that contains an abrasive is detrimental and can scratch the finish leading to corrosion.
- Aluminum polish may be used to polish small scratches and scuffs for **Stainless Steel finish.**
- Mild soap may be used to clean the product for both **Stainless Steel and Black finish.**

**FAQ's**

- 1. Hardware's are not of correct size.**  
*In GMC / Chevrolet truck model 2006 & up, customer needs to reuse the factory body bolts to install the bracket. If your vehicle is not GMC / Chevrolet 2006 & up, ensure that holes are not partially covered with any plastic grommet or rust? If it is, remove the plastic grommet & rust from the thread holes & re-try the installation.*
- 2. Mounting Bracket are not getting Installed properly.**  
*In some cases Illustration images shown in Installation manual may not be the exactly same as per actual vehicle images ,also if Driver / Passenger side mounting brackets are very identical in the design, suggest referring Parts Identification guide to avoid fitment issue.*
- 3. Products are thumping / rattling after installation.**  
*Ensure that all required mounting brackets / hardware's are installed & tighten correctly. Suggest using white lithium / regular grease between the metal to metal contact surfaces.*
- 4. Side Bar is not aligning with vehicle / Step Pads are not aligning with vehicle doors.**  
*Side bar may be interchanged or mounting brackets are not installed at the correct position in the vehicle. Refer Parts identification guide.*
- 5. Missing / Excess Hardware.**  
*Recheck hardware count as per the part list.*
- 6. Product not installing properly.**  
*Ensure make model year, cab length and bed size of your vehicle is listed in the application. All installation steps are followed correctly.*

Check out these other TrailFX Products!!

www.TrailFX.com



**BULL BAR**

**GRILLE GUARDS**

**BED RAILS**

**RUNNING BOARDS**

Keystone Automotive Operations Inc. (KAO) warrants this product to be free of defects in material and workmanship at the time of purchase by the original retail consumer. KAO disclaims any other warranties, express or implied, including the warranty of fitness for a particular purpose or an intended use. If the product is found to be defective, KAO may replace or repair the product at our option, when the product is returned prepaid, with proof of purchase. Alteration to, improper installation, or misuse of this product voids the warranty. KAO's liability is limited to repair or replacement of products found to be defective, and specifically excludes liability for any incidental or consequential loss or damage.